

# INSTRUCTIONS MANUAL

## UN SERIES

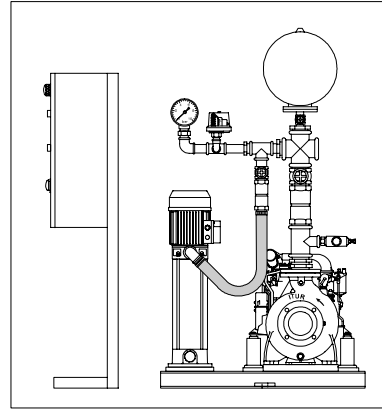
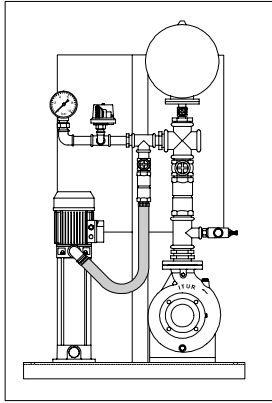

### FIRE-FIGHTING UNIT IN ACCORDANCE WITH UNE-23.500/90

## CONTENTS

MIF-4010/02-I

22-3-02

### 1.- OVERVIEW

- 1.1. Application
- 1.2. General information on the unit
- 1.3. Safety Notice

### 2.- TRANSPORT AND STORAGE

- 2.1. Packaging and protection devices
- 2.2. Storage instructions
  - 2.2.1. Battery storage
- 2.3. Transport and handling

### 3.- DESCRIPTION OF UNIT

- 3.1. Pumps
  - 3.1.1. Jockey Pump
  - 3.1.2. Main Pump
- 3.2. Motors
  - 3.2.1. Electric
  - 3.2.2. Diesel
- 3.3. Hydropneumatic accumulator
- 3.4. Impulse manifold
- 3.5. Set of valves
- 3.6. Pressure gauges and manometers
- 3.7. Control panels
  - 3.7.1. Main Jockey+ Electrical Switchboard
  - 3.7.2. Main Jockey+ Diesel Controller
- 3.8. Accessories
  - 3.8.1. Priming Pumps
  - 3.8.2. Set of Tests

### 4.- INSTALLATION

- 4.1. Positioning. Additional Safety Rules
- 4.2. Foundations
  - 4.2.1. Anchor Bolts
  - 4.2.2. Levelling
- 4.3. Alignment
- 4.4. Pipework Connections
- 4.5. Electrical switchboards
  - 4.5.1. Main Jockey + Electrical Switchboard
  - 4.5.2. Main Jockey + Diesel Controller
- 4.6. Priming Tank
- 4.7. Set of Tests

### 5.- PRIOR TO START-UP

- 5.1. Checking the pump
- 5.2. Checking the electric motor
- 5.3. Checking the Diesel motor
- 5.4. Checking the control panels
  - 5.4.1. Checking the electrical switchboard
  - 5.4.2. Checking the diesel controller
- 5.5. Overall check

### 6.- START-UP AND OPERATION

- 6.1. Starting up the unit
- 6.2. Checking instructions
- 6.3. Troubleshooting

### 7.- MAINTENANCE

### 8.- APPENDIX



## 1. OVERVIEW

### 1.1.- Application.

The content of the present manual is applicable to any fire-fighting unit described in section 3. In the event of doubt, what is indicated in the manual in Spanish prevails over the translated version.

We reserve the right to carry out modifications arising from technological innovation.

### 1.2. General information on the unit

This unit is a BOMBAS ITUR S.A product.

The fire-fighting unit is comprised of different components such as pumps, motors, couplings, etc., which each have their own instructions manual, which also must be read and followed.

### 1.3. Safety Notice

 *To prevent and avoid any risks affecting the safety of persons, facilities and the environment, special attention must be paid to the information given in the manuals of the pumps comprising this unit.*

 *All regulations applying in the country of use must also be taken into account and complied with.*

 *Unauthorised modifications are forbidden. Any modification to the unit must be previously consulted with KSB ITUR.*

## 2. TRANSPORT AND STORAGE

### 2.1. Packaging and factory protection devices

Following the painting phase, BOMBAS ITUR S.A carries out the following processes:

- All the openings are sealed by means of plastic parts or plastic adhesives.
- All visible non-rust surfaces are covered by means of temporary protective peeling varnish.
- Depending on the kind of packaging ordered, they are either placed on a wooden pallet and covered with heat-weldable plastic, or they are put in a slatted or fully closed wooden crate.
- In all cases the units are firmly secured in order to avoid displacement during transport and handling.

These protection measures are intended for transport only and at most for storage over a short period of time. In any event, the following storage instructions must be fulfilled.

### 2.2. Storage Instructions

#### WARNING

*These instructions are for storage periods of under 12 months from the dispatch date. Should the period be longer, please ask for long-term storage instructions.*

#### Before storage:

- The unit must be stored indoors, protected from bumping and humidity.
- Pumps and auxiliary conduits must be clear of pumped liquid.
- You are advised to cover the unpainted parts of the pump with protective material (such as Vaseline or similar).

 *Electric motors must be disconnected and connection cables removed; terminal boxes must be closed, with their covers on.*

- Electrical switchboards must be in vertical position and must be disconnected.

#### Following storage:

- Remove the temporary protection devices and visually check the condition of all the components.
- Follow the specific post-storage instructions in the pump, motor and other manuals.

- Connect the unit and the panels according to the attached diagrams. Follow the assembly instructions.

- Observe the other steps indicated in the "start-up" section.

### 2.2.1. Battery Storage

The Diesel motor starter batteries are normally charged when dispatched except for export destinations and specific order requests. In each case, the following steps must be followed:

#### Charged Batteries:

- If these batteries are going to be in storage for periods of over 1 month, they must be connected periodically to an appropriate charger to avoid them falling below charge threshold level and becoming useless.

#### Dry Batteries (uncharged):

- These batteries are supplied with the acid in separate recipients. During storage, keep these recipients clearly marked and identified.
- Following storage, the batteries must be filled with the acid and left to stand for at least 1 hour. After this the batteries will be sufficiently charged to start up the Diesel motor.

 *The acid in the recipients is seriously hazardous if it comes in contact with the skin or eyes and special precautions must be taken (e.g. use of gloves, suitable clothing and goggles) when handling.*

### 2.3. Transport and handling

 *The unit must be transported and handled using means that are appropriate for the weight to be carried. The weight is usually indicated on the delivery note or on the nameplate; if this is not the case and safe handling of the unit not guaranteed, please contact us to let us know the situation. The units should never be piled on top of one another.*

For handling, units that so require are equipped with appropriate eyebolts on the base. However, remember that the units should never be hoisted by means of the eyebolts on each of their elements; for example motor and pump eyebolts, which are designed exclusively for independent transport of these parts. Pump and piping flanges or joining elements such as couplings should not be used either.

## 3. DESCRIPTION OF UNIT

The UNE fire-fighting unit supplied by BOMBAS ITUR S.A may contain one or several pumps with their motors and control panels and another series of components, depending on the unit requested. The different items that may comprise a fire-fighting unit are listed below.

The sound-pressure level of these pumps when the Diesel motor exhaust silencer is in place, is under 100 dB (A) at any stage during operation (as long as the flow is above the minimum flow required for each model). The sound power is under 110 dB(A).

### 3.1. Pumps

#### 3.1.1. Jockey Pump

Low flow pump whose purpose is to maintain the pressure in the unit. Supplied with electric motor.

#### 3.1.2. Main Pump

Pump intended to cover the nominal flow of the fire-fighting unit. Normally driven by an electric or Diesel motor.

#### WARNING

*Remember that each type of pump has its own instructions manual.*

### 3.2. Motors

#### 3.2.1. Electric

The motors are supplied with minimum protection of IP-54.

### 3.2.2. Diesel

Industrial air cooled injection motor for four-phase steady-state service; comes with the following accessories:

- Air, fuel and oil filters
- Silencer
- Belt protection (if necessary)
- Electrical start-up unit
- Electrically operated stop valve
- Pressure switch and oil pressure transmitter
- Motor temperature thermo contact
- Magnetic sensor
- Panel with tachometer (rpm counter), hour meter, oil-pressure pressure gauge
- Fuel tank
- Double set of starter batteries
- Two emergency power buttons

**WARNING** Remember that each type of motor has its own instructions manual.

### 3.3. Hydropneumatic Accumulator

The hydropneumatic accumulator, whose function is to maintain the pressure in the circuit, is connected to the impulse manifold by a sluice valve.

The standard size is 25 litres at 8 kg/cm<sup>2</sup>.

### 3.4. Impulse Manifold

Connecting pipe for the impulse of all the pumps. It is designed so that the flow does not exceed the speed of 3 m/s, for nominal flow.

### 3.5. Valve Set

Sluice Valves. All the pump impulses are equipped with a sluice valve. There are also valves for isolating the accumulator.

Check Valves. All the pump impulses are equipped with a check valve.

Limiting Valves. All the main pump impulses are equipped with a factory-set limiting valve.



The outlet should be conducted to a suitable drain to avoid damage to property or persons. No other valve should be intercalated.

### 3.6. Pressure switches and Pressure Gauges

Each unit is supplied with the following pressure switches and pressure gauges:

- Placed after the sluice valve of the Jockey pump:
  - \* A Jockey pump start / stop pressure switch
  - \* A main pump start pressure switch
  - \* A pressure gauge to indicate the pressure in the impulse manifold

### 3.7. Control Panels

All the cabinets are made of sheet metal, with hinges and closing tabs.

A copy of the electrical diagram is displayed inside them.

All the panels are supplied with a steel base, which, in the event of the unit comprising electrically driven pumps only, will be found attached to the general bed, fully connected. When the control panels are supplied separately from the main bed, they will be sent connected with a minimum of 3 metres of cable.

### 3.7.1. Main Jockey + Electrical Switchboard

Adequate protection against overcurrent in the main unit will be provided by magnetic fuses or circuit breakers.

The electrical diagram is displayed inside each cabinet.

#### - Control Items

- \* *Jockey pump operation selector.* This is a 0-AUTomatic selector for the Jockey pump, with the following positions:

#### Pos. 0:

The Jockey pump stops, whether or not it has received a start-up order from the pressure switch.

#### Pos. AUT:

The Jockey pump can be operated automatically by means of a pressure switch signal.

- \* *Main pump operation selector.* This is a 0-MANual-AUTomatic selector for the main electrical pump. It has the following possibilities:

#### Pos. 0:

The main pump stops, whether or not it has received a start-up order from the pressure switch.

#### Pos. MAN:

The main pump can be put into operation manually by pressing the "ON" button.

#### Pos. AUT:

The main pump can be operated automatically by means of an order from the relevant pressure switch.

- \* *"On" Button:* Button for starting the main pump manually. This feature only works if the pump operation selector is in "MAN" position.

#### - Measuring Instruments

- \* *Start counter:* Counts the number of times the Jockey pump is started.
- \* *Voltmeter:* Indicates the voltage of the input line to the control panel when this is connected. Equipped with a phase switch.
- \* *Amperemeter:* Indicates the current consumed by the main pump motor.

#### - Optical Alarms and Functions

- \* *Connected:* A green light is switched on when the panel is connected to the electricity supply. It should normally be on.
- \* *On:* A green light is switched on when the main pump is operating.
- \* *Start-up failure:* A red light switches on when the main pump has been switched on but fails to start up.
- \* *Insufficient water:* A red alarm light switches on to indicate insufficient water in the suction tank, provided a buoy has been installed (not included in standard supply), or when the water level is low (60%) in the priming tank (if it is included).
- \* *Protection device trip:* A red light switches on when there is a fuse failure or a fault in any of the phases.
- \* *Voltage fault:* A red light switches on when there is insufficient voltage on the switchboard.

#### - Sound Alarm

On the front of the panel there is a very powerful sound alarm supplied by a small battery with its relevant charger. It goes off in the event of:

- Voltage shortage
- Main pump start-up fault
- Low water reserve level
- Low priming level

### 3.7.2. Main Jockey + Diesel Panel

The electrical diagram is located inside the panel.

#### - Control Items

\* *Jockey pump operation selector*: This is a 0-AUTomatic selector for the Jockey pump, with the following positions:

Pos. 0: The Jockey pump stops, whether or not it has received a start-up order from the pressure switch.

Pos. AUT: The Jockey pump can be operated automatically by means of a pressure switch signal.

\* *Pump motor operation selector*

Pos. 0: Pump put of service.

Pos. "MAN" (Manual): Enables manual start-up using the button. Acts directly on the starter motor independently of the automatic control. All the alarms are operative.

Pos. "AUT" (Automatic): Enables automatic start-up when there is a pressure drop in the water system. When the unit receives an automatic start-up order it begins a cycle of start-up attempts lasting 15 sec. with battery stand-by periods of 6 sec.

If there is no request, the unit is stopped by pressing the manual stop button.

Pos. "TEST": Simulates the request for carrying out routine maintenance processes.

The unit stops when the stop button is pressed.

#### - Measuring Instruments

\* *Start Counter*: Counts the number of times the Jockey pump is started up.

#### - Start-up Detection

The unit is equipped with a tachometric relay for detection purposes.

#### - Optical Alarms and Functions

The following light signals are located on the panel:

\* *Voltage*: A green alarm light switches on when the electricity supply is available.

\* *Voltage failure*: A red alarm light switches on to indicate a voltage failure.

\* *Low motor oil pressure*: A red alarm light switches on to indicate low pressure in the lubrication circuit.

\* *High motor temperature*: A red alarm light switches on to indicate excessively high temperature in the motor.

\* *Insufficient water*: A red alarm light switches on to indicate a shortage of water in the suction tank, provided a buoy has been installed (not included in standard supply), or when the water level is low (60%) in the in the priming tank (if it is included).

#### - Sound Alarm

The system incorporates a siren that is triggered in the event of:

- Voltage shortage / Electricity supply fault
- High motor temperature
- Low motor oil pressure
- Low water reserve level
- Low priming level

#### - Charging the Batteries

The unit has a charger capable of maintaining the batteries fully charged by supplying current until the rated service voltage is attained and subsequently providing a lower maintenance current.

### 3.8. Accessories

#### 3.8.1. Priming Tanks

When the unit is operating in suction, with the aim of guaranteeing that the pumps are primed at all times, a priming pump can be incorporated to each pump, at a higher level than the pump itself and connected to its impulse.

When specifically requested BOMBAS ITUR S.A can supply the priming tank but does not supply the related accessories or support bases, which must be put in place by the installer.

#### 3.8.2. Set of Tests

BOMBAS ITUR S.A is in a position to supply a deviation as described below for placing after the impulse manifold for unit tests:

- T Derivation
- Isolation valve
- Rotameter type flowmeter

## 4. INSTALLATION

### 4.1. Location. Additional Safety Rules



- The area in which the units are to be installed should be well ventilated to avoid accumulation of fumes from the battery and combustion gases from the motor.

- Establish an earth connection on the bed and electric motor.
- Place the Diesel motors at a distance from the electrical material.
- Prepare an appropriate evacuation system for the Diesel motor exhaust gases.
- Separate the electrical switchboard and its connection cables from the areas that heat up due to the influence of the Diesel motor.
- Follow the wiring instructions according to the attached diagrams and those incorporated on the switchboards.
- The connections from the impulse connector to the system must be established following the diagrams provided.
- When the unit is installed in a closed area, at least the following must be seen to:
  - \* Provide a drain in the floor for the evacuation of drainage liquid and liquid from leaks in the pump close area.
  - \* Sufficient ventilation to avoid the motors overheating.

The diameters of the pipes, valves and accessories must be calculated in terms of the foreseen load losses in the unit, such that the liquid speeds are:

- *Speed in impulse pipe*: from 2 to 3 m/s.
- *Speed in suction pipe*: from 1 to 2 m/s.

If the pump suction needs to be reduced, it must be excentric, with the generatrix in the upper part.

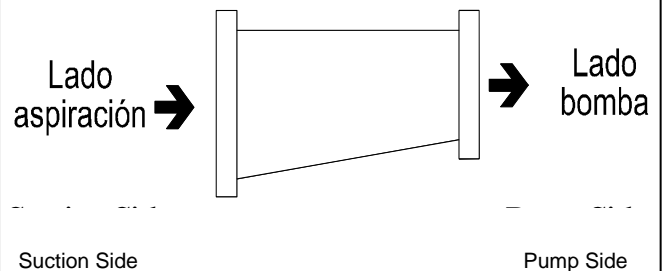

### 4.2. Foundations

#### WARNING

*The unit must be placed on a sufficiently large foundation. This foundation must be completely flat, smooth and level.*

The unit must be secured to this foundation by means of appropriate anchor bolts to avoid possible vibrations arising during operation.

#### 4.2.1. Anchor Bolts

KSB ITUR can supply such tools, which are put in place as follows:

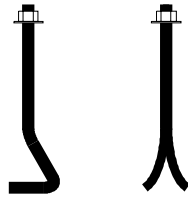

- Place the unit on the foundation.
- Make the holes required for situating the bolts on the brace points in the foundation.
- Carry out an initial levelling procedure.
- When the unit is placed on the foundation, with the bolts in the holes, pour the grout on to the holes (do not use quick-dry cement) and leave to dry for 48 hours.
- Level once more and tighten the bolts

#### 4.2.2. Levelling

A conventional bubble level should be used for levelling; the levelling procedure should be carried out both longitudinally and transversely with respect to the unit.

If the bed needs to be wedged, you are advised to use small plywood wedges, which should be joined together with grout and water in order to provide a reliable joint and avoid subsequent deformation when the bolts are tightened.

When the process is finished you are advised to assemble a locknut on the bolt nuts in order to avoid them coming loose during the operation of the unit.

#### 4.3. Alignment

When a diesel unit is supplied, the pump-motor has previously been aligned at the factory, but due to carriage and to fastening to the foundation, it should be realigned before start-up.

##### **WARNING**

The unit must always be aligned when it is has been fully assembled and before start-up.

To carry out the alignment process, refer to the instructions indicated in the particular manuals of the unit pumps.

#### 4.4. Pipework Connections

The flanges must be placed in absolutely parallel fashion in order to minimise strain on the necks of the pumps, which may deform them or lead to shaft misalignment. The screws or studs must be able to pass easily through the holes in the flanges. Do not forget to place connections between the couplings.

In order to avoid impeding the suction, you are strongly recommended to install the pumps with independent pipes for each one.

##### **WARNING**

*Do not use the pump as an installation fastening point. Use independent bracing to bear the weight and strain of the piping*

You are recommended to use antivibratory sleeves between the general manifold outlet and the fire protection water supply.

#### 4.5. Electrical switchboards

All the input terminals are numbered. These connection terminals are as follows:

##### 4.5.1. Jockey panel + 1 main Electrical switchboard.

##### INPUTS:

- \* **Jockey pump:** Connection for direct start-up from the Jockey pump.
- \* **Earth:** Contact for earth connection.
- \* **Pump 1:** Connection for star-triangle start-up of main electric pump.

- \* **Jockey Pressure switch:** Pressure switch contacts for Jockey pump start/stop signal.

- \* **B1 Pressure switch:** Pressure switch contacts for main electrical pump start-up signal.

- \* **Tank water low:** Connection to buoy or level probe detecting low water level in the suction tank.

- \* **Priming Tank 40%:** To connect the outlets applying to the 40% priming tank level (see section 4.8. of this manual). In the event of a signal, the panel automatically issues an order to start up the motor to avoid depriming of the pump.

- \* **Priming Tank 60%:** Same, but at 60%.

#### 4.5.2. Jockey + Main Diesel Pump Controller

##### INPUTS

In the controller for connection with the rest of the system, there are terminals for the different input signals:

- \* **Earth:** Input for connecting the earth cable.

- \* **Supply voltage:** Supply with 380 V. 50 Hz. (Others in the event of special orders).

- \* **Mass:** Supply with negative of both starter batteries.

- \* **Battery "A":** Input for + of battery "A".

- \* **Battery "B":** Input for + of battery "B".

- \* **Priming tank at 40%:** To connect the relevant outputs to the 40% priming tank level (see section 4.8. of these manual). In the event of a signal, the controller automatically orders the motor to start up to prevent the pump from depriming.

- \* **Priming tank at 60%:** To connect the relevant outputs to the 60% priming tank level (see section 4.8. of this manual).

- \* **Magnetic Sensor:** Inputs of magnetic sensor of motor.

- \* **Start-up request:** Inputs for connecting the start-up request pressure switch of the Diesel pump motor, which is located in the Jockey pump impulse.

- \* **Motor oil pressure:** Input for the Diesel motor oil pressure sensor or tell-tale valve. This sensor is a contact that is usually closed.

- \* **Motor temperature:** Input for the Diesel motor oil pressure sensor or tell-tale valve. (contact usually open)

- \* **Low water level:** Inputs for connecting the buoy or probe that detects the low water level of the suction tank. If this contact closes, only an alarm indication is given.

##### OUTPUTS

The unit is equipped with switch-operated output contacts.

- \* **Battery Start-Up:** Outputs for leading to the starter contactors of batteries "A" and "B":

- \* **Electrically operated stop valve:** Output for supply of Diesel motor stop solenoid.

- \* **Sensors:** Supply to Diesel motor sensors (tachometer, rpm counter, temperature sensor and pressure sensor)

#### 4.6. Priming Tank (optional)

If the priming tank, is supplied proceed as follows for assembly:

- Dismantle the pump impulse safety valve.

##### **WARNING**

- Using a "T" connect the output from the lower part of the priming tank to the area in which the safety valve was assembled. Do not forget to reassemble the safety valve at the other end of the "T".

- Connect the mains water in the 1/2" GAS water inlet of the priming tank.

- Assemble the cover of the priming tank. The probes will automatically be located at the appropriate levels.
- The float valve inside the tank will allow water to enter the tank until the required level is attained.
- Lead the overflow outlet to a drain.
- Carry out the electrical assembly. For this purpose see the attached diagrams and follow the instructions below:
  - \* Connect the terminals applying to the 40% level of the priming tank controller to the pump controller terminals.
  - \* Repeat the operation with the terminals of the priming tank controller that apply to the 60% level.

#### ELECTRICAL TERMINALS:

- \* **40%:** 40% level output indicator with contact normally open.
- \* **60%:** 60% level output indicator with contact normally open.

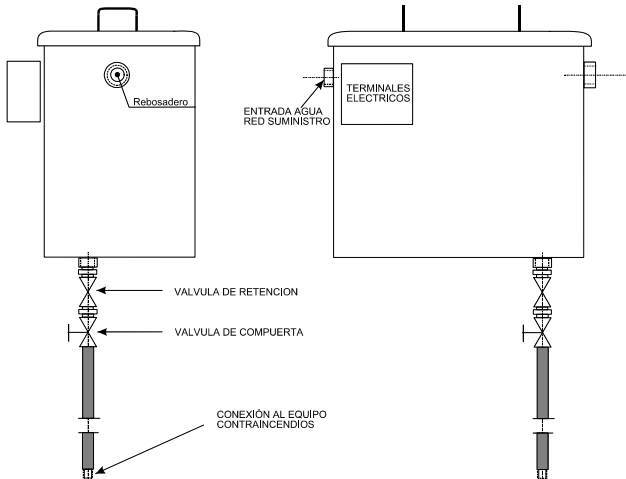

#### 4.7. Set of Tests (optional)

The set of tests is placed after the impulse manifold. It comprises a T, a sluice valve and a rotameter-type flowmeter (this is supplied separately) .

For the rotameter to work properly, it must be installed in accordance with the attached drawing (DN = nominal diameter of the rotameter).

The pressure switches must be placed on the same level and therefore horizontally. These piping stretches are NOT supplied by KSB ITUR, unless they are specifically ordered.

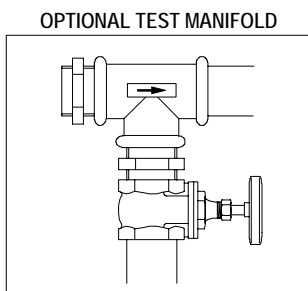

### 5. PRIOR TO START-UP

#### 5.1. Checking the pumps

**WARNING** For the different checks, refer to the pump instructions manual.

#### 5.2. Checking the electric motor

**⚠** When the electrical connection is being established, it is absolutely essential to ensure that the kind of current and rated voltage indicated on the motor name plate coincide with the kind of current and electricity supply voltage in the installation area.

Leave room for the separation required between the motor and the walls in order to provide sufficient cooling.

**WARNING** Check the points indicated in the particular electric motor manual.

#### 5.3. Checking the Diesel motor

Check that the motor tank is connected and filled with fuel.

**⚠** In closed areas, ensure that the exhaust pipe is properly connected to smoke exhauster to avoid intoxication hazards..

Check that the batteries are charged and connected (see pt. 2.2.1). If the charge is low, the battery should be left to charge for at least one day before start-up.

Check the motor oil level.

**WARNING** Follow all the other indications in the particular Diesel motor manual carefully.

#### 5.4. Checking the controllers

**⚠** When the electrical connection is being established, it is absolutely essential to ensure that the kind of current and rated voltage indicated on the panel coincide with the kind of current and electricity supply voltage in the installation area.

##### 5.4.1. Checking the Electrical Switchboard

Before connecting the switchboard to the line, you must:

1. Check that the input/ output connections coincide with the electrical diagram that accompanies the switchboard.
2. Reset all the inner relays if they are tripped.
3. Check fuses and connections, as they might have become loose during transit.
4. Set all the selectors in Pos.0

##### 5.4.2. Checking the Diesel Controller

With the battery and electricity supply connected, check that the voltage in the plate terminals is correct.

- Supply voltage.
- Battery voltage.
- Battery voltage. Mass.

#### 5.5. Overall Check

- Ensure that the pressure value in the air chamber of the hydropneumatic accumulator coincides with that indicated on the accumulator or is 0.2 kg/cm<sup>2</sup> less than the starting pressure of the main pump with the lowest regulation.
- If you do have a flowmeter, to obtain an appropriate reading, check that it is installed as indicated in point 4.7 of this manual.
- If it is equipped with a suction and priming tank, check that they have the required water level.
- Check the pressure switch, buoy and probe connections to the controllers.

### 6. START-UP AND OPERATION

#### 6.1. Starting Up the Unit

- Before starting up the unit, check all the sections in the "PRIOR TO START-UP" section.
- Connect the suction pipes, together with their valves and elbows, to the suction flanges of the pumps; and the main fire protection water supply piping to the impulse manifold.
- The unit must be started up with the suction and impulse valves fully open.
- Set the Jockey pump selector to position "AUT" (Automatic), leaving the main pumps at "0". At this point, if the network is empty, the Jockey pressure switch will order it to operate and the "Jockey ON" pilot light will switch on.
- The hydropneumatic accumulator and the entire fire protection system begin to fill.
- The pilot pump (Jockey) will gradually come to a stop as the system fills up. At this point, there is water at full pressure throughout the system.

**WARNING** Look out for possible leaks that might take place in the system.

- When you have finished filling the system and with the Jockey stopped, set the selectors of the main pumps of their respective control panels in automatic operation position to leave the unit in normal alert mode.

\* If the unit is equipped with a test manifold, use it to start up the Diesel pump motor automatically, partially opening the sluice valve.

\* If there is no test manifold, set the operation selector of the Diesel pump control panel to MANUAL position and start up the pump by pressing the start button. If possible, open a water outlet point in the impulse.

\* Stop the Diesel pump by pressing the stop button.

\* Set the main pump selectors to "AUTOMATIC" alert position, after having passed through "0".

**WARNING** *Whenever you want to place a selector "AUTOMATIC" position, you must first pass through the "0" position.*

### 6.2. Checking Instructions

Due to the fact that the normal status of the unit is "alert", with the pumps stopped, before carrying out the periodic start-up indicated in the regulations, check that:

1. The suction and impulse valves are fully open.
2. On the electric motor switchboards:
  - Operation selectors in AUT (automatic) position
  - Pilot lights indicating presence of voltage on.
  - Correct voltage in the voltmeter in the three phases.
  - Absence of activated alarm indications.
3. In the Diesel motor control panels:
  - Operation selector in position 3 (automatic).
  - Absence of activated alarm indications.
  - The following pilot lights should be on:
    - \* Presence of voltage
4. There is pressure in the system by means of the pressure gauge located after the Jockey pump impulse.
5. Absence of leaks through piping and pump joints.
6.  All the unit protection devices are in place (e.g. the pump connection guards).

### 6.3. Troubleshooting

**WARNING** *With regard to pump or motor anomalies, refer to the particular manual applying to each of these items.*

The control panels of the fire-fighting units have a complete series of alarms that detect and warn about possible anomalies that can come about during operation. Therefore, any time an alarm is triggered, refer to the particular alarm type specified in this manual.

However, below is a list of anomalies whose causes may not be very clear, even though the related alarm is included on the panel:

#### In the Jockey:

##### 1.- Pump Overload Alarm

\* Check Jockey pump protection devices (motor protector)

- The Jockey pump stops and starts repeatedly due to a breakage in the hydropneumatic tank or to a leak in the impulse circuit.

#### In the Main Diesel Pumps:

##### 1.- Low Voltage / Supply Fault Alarm

- \* Faulty Connections
- \* Low Supply Voltage

##### 2.- Low Motor Oil Pressure Alarm

- \* There is no oil
- \* Oil transmitter out of order

##### 3.- High Motor Temperature Alarm

- \* External Cooling Circuit Obstruction

##### 4.- Low Water Reserve Level Alarm

- \* Insufficient water in suction

##### 5.- Low Priming Level Alarm (optional)

- \* Leak through the foot valve of the pump
- \* Water input to tank obstructed, or lack of water
- \* Priming tank dry

#### In the Main Electrical Pumps:

##### 1.- Low Water Reserve Level Alarm

- \* There is no water in suction

##### 2.- Protection Device Trip Alarm

- \* Main pump fuses out of order

##### 3.- No Voltage Alarm / No automatic

- \* There is no supply voltage

## 7. MAINTENANCE

Before proceeding to the assembly/dismantling of any unit, first safely disconnect from the electricity supply or disconnect the relevant motor battery cable, close the sluice valves and empty the unit after having removed its pressure.

- Check the units in accordance with the manuals for the pumps and their motors and also the spare parts needed for them.
- Regularly check the pressure gauge regulation and the air in the hydropneumatic accumulator.
- If any accessory (pressure switch, etc) is dismantled for maintenance, it must be reassembled properly in the same position as it was originally.
- Parts of the Diesel motor heat up considerably. Take care not to touch them accidentally. Use gloves.
- Units must be safely disconnected before any revision is carried out.

## 8. APPENDIX

**WARNING** *Due to the wide variety of controllers requested, the relevant electrical diagrams are displayed inside them. For greater safety, we advise you to keep a copy of them with this manual.*

---

---

---

---

---

---

---

---

---

---

# EC CERTIFICATION

**BOMBAS ITUR, S.A.**

Camino Urteta, s/n Zarautz- (Gipuzkoa)- Spain

**PRODUCT BEING CERTIFIED: "UN" FIRE-FIGHTING EQUIPMENT**

## "CE" DECLARATION OF CONFORMITY

*BOMBAS ITUR, S.A. herewith declares, on its own responsibility, that the above-mentioned products, which it manufactures (if supplied with an engine), and to which this Declaration is related, meets that set down in European Directives 98/37/CE, 89/336/CEE, 73/23/CEE on the laws of approximation of Member States with respect to machines.*

*Harmonised rules applied:  
EN 292 Part 1 and EN 292 Part 2.*

## MANUFACTURER'S DECLARATION

*BOMBAS ITUR, S.A. herewith declares that its above-mentioned products (if supplied without an engine) are intended for fitting to machinery or for assembly with other machines in order to constitute the machinery covered by Directives 98/37/CE, 89/336/CEE, 73/23/CEE.*

*Note: this pump cannot be installed until the machinery to which it is to be fitted has been passed according to the stipulations of the previously mentioned Directive.*

*Harmonised rules applied:  
EN 292 Part 1 and EN 292 Part 2.*

ZARAUTZ, 21/02/2006

Position

President

Name

Juan Antonio Uriarte

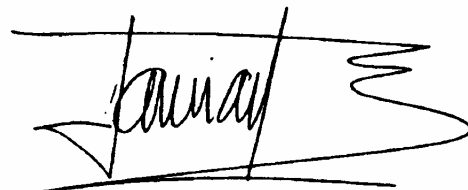

**BOMBAS ITUR, S.A. (KSB Group)**

P.O. Box 41 – 20800 ZARAUTZ (Gipuzkoa) Spain

Tel.: +34 943 899 899 – Fax +34 943 130 710

E-mail: [postventa@itur.es](mailto:postventa@itur.es) – [www.itur.es](http://www.itur.es)