

INSTRUCTIONS MANUAL

BP, TR, TS, CC, MC, GC, JET, NBC, FILTER, CA, CCX, MCX, INOXJET, NBX, SILEN MONOBLOCK SURFACE PUMP

MIF-6000/02-I

06-01

1. RECEPTION

When you receive the device, check that the packaging is in good condition. If this is not the case, indicate it in writing on the transport company's delivery note, unpack the device and check its condition. If there is any damage, inform the distributor immediately.

2. SAFETY INSTRUCTIONS

In this manual, the important safety instructions are specifically marked. These marks show the following symbols:

 Safety instructions which if not complied with could affect the safety of people and installations.

 Safety instructions to prevent electrical risks (hydrocution, etc.).

WARNING Safety instructions which if not complied with could affect the system and its operation.

 All the equipment supplied by **BOMBAS ITUR** is suitably protected to avoid possible accidents, however, in all cases, all the safety recommendations indicated on the pump, in the documents supplied with it or in the applicable regulations must be complied with.

If they are not complied with **BOMBAS ITUR S.A.** will be exempt from any responsibility.

The indicated safety recommendations are based on our experience and on normal use of the equipment.

It is the exclusive responsibility of the installer/user to evaluate the individual risks that exist in each installation and to prevent its connection and start up without the appropriate protections.

3. GENERALITIES

 The user must not carry out operations that are prohibited in this manual. All operations or handling must always be carried out with the appropriate means, by suitably trained staff and after having read and understood this manual.

 Any installation, maintenance, repair or transport operation must be carried out when the pump is stopped and safely disconnected.

 The good condition of both the electrical and the pipe installation must be checked periodically. If the pump is not in a safe condition, it must be stopped and

repaired. This is especially important if the defects are found in electrical devices or cables.

 In the area surrounding the pump, avoid any element which could get trapped by moving parts, such as loose clothing or long hair.

 When the system is started by pressing the switch or connecting it to a socket point, make sure that it is carried out on dry ground and never with wet hands and/or without appropriate footwear.

 Before starting up the pump, all of its elements, especially those concerning safety, must be correctly installed and fixed.

4. LOCATION

 The access to the pump or installation must be sufficiently restricted so that no one can access it inadvertently. Safety elements must be fitted which prevent access by children or other people at risk.

 The pump must NOT be installed in areas classified as having a risk of explosion.

WARNING The pump must be installed in a sufficiently spacious area which enables its cooling process. The ambient temperature should not go over 40°C.

The pump must be protected against frost, against the direct continuous action of the sun (temperature) and against possible projections of liquid.

If the pump is going to be installed at altitudes of over 1,000 m, take into account the subsequent loss of power in the motor.

WARNING If the pump is installed outdoors with a risk of frost and it is not going to be used, empty it to prevent damage caused by the liquid freezing.

If the pump is not going to be used for a long period of time, it should be emptied and stored in a dry, well-ventilated place.

5. PUMPING LIQUID

The pumps must never work without liquid.

 The pumps referred to in this manual, have been designed for use with clean water. (Except the Type CA pumps which are also valid for use with gas oil).

In all cases, as a general norm, the pumping liquid must **NOT** be any of the following:



- Dirty, aggressive, corrosive, inflammable, toxic or explosive.
- Of a higher temperature than that indicated as the maximum for each model.
- Carrier of solids, salts or solvents.
- Viscous (except CA).

6. INSTALLATION

 Both the user and the installer must strictly follow all the applicable safety standards, laws and regulations.

The pumps must be installed on a solid horizontal base and be held down with screws.

It is advisable to install the pump as close as possible to the water source, except in services for swimming pools, in which the pump must be installed at least 2 m from the edge of the swimming pool.

The difference in height between the level of the liquid and the pump must be as small as possible.

The suction pipe must be rigid, as short as possible, and always upward in order to prevent air pockets from forming. Its end must remain submerged at a depth two times the diameter of the tube or at least 15 cm. If the pump does not have automatic suction, fit a foot valve or a non-return valve. If there is a possibility of the appearance of solids, install a correctly dimensioned filter. It is recommended to fit a valve which allows the pump to be separated from the installation.

In the discharge pipe, fit a regulating and isolation valve next to the pump and behind this, a non-return valve.

Both the suction pipe and the discharge pipe must have a diameter equal to or greater than the pump inlets. They must never rest on the pump; independent elements must be present to support the pipes.

7. ELECTRICAL INSTALLATION

 The electrical connections must be made by qualified staff, strictly abiding by the standards and recommendations for the prevention of accidents.

 The earth connection cables must be the first to be connected, and the last to be disconnected.

WARNING The electrical connections to the pump must be made in accordance with the diagrams indicated in this manual.

 The characteristics of the mains (voltage, frequency, etc.) must correspond with the values indicated on the name plate. A variation of the voltage of up to 10% is admissible.

A phase imbalance of up to 5% is admissible. If greater values are observed, check the values with the other cable connection combinations (without changing the turning direction). If the highest value is always given in the same phase of the line, the cause of the imbalance is most likely to be in the mains network.

The electrical installation must have the following:

- An appropriate earth connection.

 • An omni-polar disconnection system (for all the phases) with opening of contacts of at least 3 mm of separation.

- A highly sensitive current operated circuit breaker (0.03 A).

 • In the event that the motor does not incorporate heat protection, protection must be installed on the board.

- The supply cable must be H07 RN-F type according to VDE 0250.

The use of scarcely dimensioned or low quality components in the electrical installation will lead to rapid wear of the contacts, with the consequent wear of the motor, due to an imbalance in the power supply.

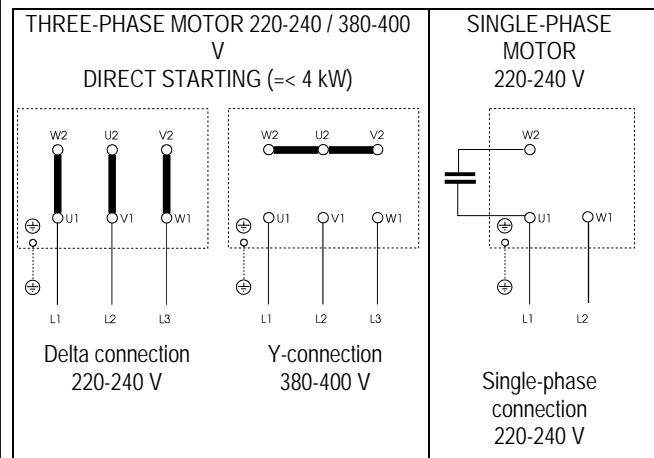

FOR 380-400 / 600-690 V MOTOR, THE POWER WILL NORMALLY BE EQUAL OR GREATER THAN 5.5 kW (7.5 HP) AND THEREFORE IT MUST BE STARTED IN Y-DELTA.

8. START UP

Before starting up the pump, check that all of its safety and protection elements, such as terminal box covers, fan covers etc. are correctly installed and fixed.

Manually turn the pump to break all the adherence.

Fully open the suction and discharge valves. Remove the pump cover and proceed to fill it. Replace the cover.

Partially close the discharge valve

(Only three-phase pump). Start the pump for an instant and check that the turning direction corresponds with the marked direction. If this is not the case, swap the position of two of the phases.

Start the pump. Check that there is no evidence of incorrect operation such as excessive noise or vibrations.

9. OPERATING ANOMALIES

- 1) The pump does not start.
- 2) The pump starts but has no pressure.
- 3) The pump starts and stops continuously.
- 4) The pump starts but has no flow.
- 5) The motor heats up in excess.
- 6) The rotor turns with difficulty.
- 7) Excessive noise or vibrations.

This page has deliberately been left blank

1	2	3	4	5	6	7	POSSIBLE CAUSES	SOLUTIONS
	X		X				Pressure generated by the pump is less than required by the installation	Check the load losses and the geometric height
	X		X			X	Insufficient suction	Improve suction. Increase Ø of pipes, remove unnecessary accessories
		X		X			Density or viscosity of the liquid	Change the pump for a more suitable one
	X		X				Pipe diameters insufficient	Install pipes with greater diameter
	X		X			X	Air enters through the sealing system	Call official technical service
	X		X			X	Air enters in the suction pipe	Check hermetic integrity of pipe/valves
		X		X	X	X	Bearings worn	Call official technical service
						X	Lack of rigidity in the foundation or anchor bolts loose	Reinforce the foundation or tighten bolts
		X		X		X	Required pressure lower than assumed pressure	Regulate the discharge valve
	X		X			X	Incorrectly filled	Refill the pump and the pipes
	X		X				Pipes blocked	Clean pipes
	X	X	X	X	X	X	Obstruction inside the pump	Call official technical service
			X				Turning direction incorrect	Change the motor's connections
					X	X	Tensions of the pipes on the pump	Brace the pipes and level the system
	X		X				Filling incorrect	Fill the installation correctly
X			X	X			Incorrect electrical voltage	See data on name plate
	X		X	X		X	Suction or discharge valves incorrectly regulated	Open the suction valve completely, and find the working point with the discharge
X							Fuses or thermals disconnected	Connect them and reset them
		X		X			Bad ventilation	Improve the ventilation

10. GUARANTEES

The non-compliance of what is indicated in this manual implies the inappropriate use of the system from the technical and safety point of view, and therefore **RELIEVES BOMBAS ITUR FROM ANY RESPONSIBILITY IN THE EVENT OF PERSONAL ACCIDENTS OR MATERIAL DAMAGE, AND WILL ALSO LEAD TO THE LOSS OF ALL RIGHTS TO CLAIM THE GUARANTEE.**

One year's guarantee is established against all design or manufacturing defects and it is the customer's responsibility to cover the cost of transporting the system to our installations or those of our official technical services and the travelling expenses of our staff to the installation if required.

Any handling of the system by the customer, without our written consent, implies a loss of all rights to claim the guarantee.

"CE" DECLARATION OF APPROVAL

BOMBAS ITUR, S.A. herewith declares, on its own responsibility, that the above-mentioned products, which it manufactures (if supplied with an engine), and to which this Declaration is related, meets that set down in European Directives 98/37/CE, 89/336/CEE, 73/23/CEE on the laws of approximation of Member States with respect to machines.

*Harmonised rules applied:
EN 292 Part 1 and EN 292 Part 2.*

ZARAUTZ, 21/02/2006

Position: President
Name: Juan Antonio Uriarte

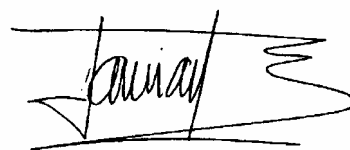

BOMBAS ITUR, S.A. (KSB Group)

P.O. Box 41 – 20800 ZARAUTZ (Gipuzkoa) Spain

Tel.: +34 943 899 899 – Fax +34 943 130 710

E-mail: postventa@itur.es – www.itur.es